

Maßtabelle

LAS-System (PP/Edelstahl)

Konzentrische Abgasanlage
DÖRING-LAS (PP / Edelstahl)
mit zylindrischer Steckverbindung,
Innenrohr PP 2,00 mm inkl. Dichtungen
Außenrohr Edelstahl 0,5 mm
1.4509 (441), glänzend

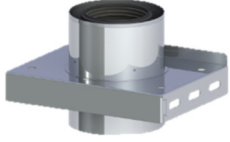
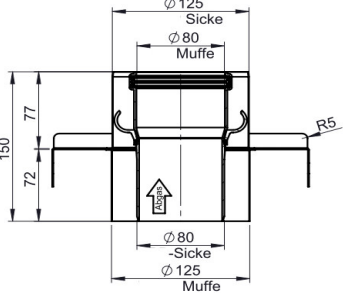
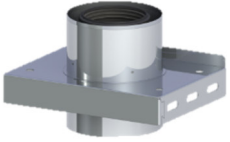
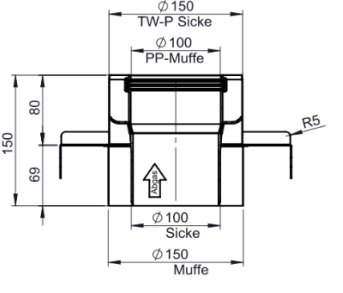
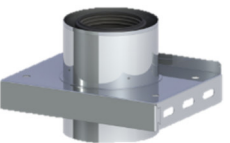
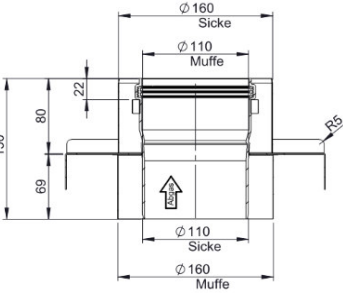
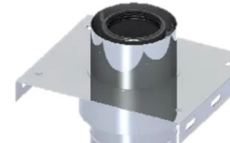
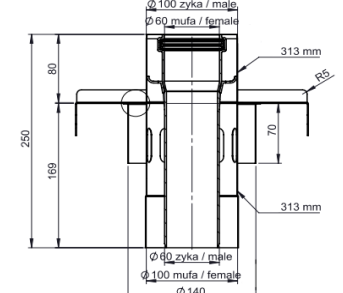
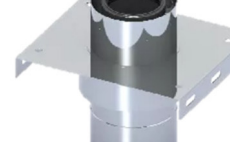
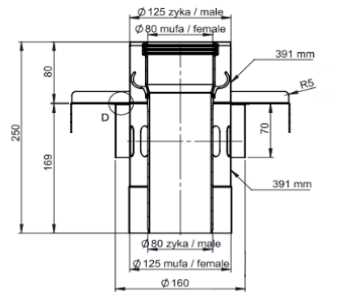

	<p>Wandkonsole mit Querstrebe Type 391 max. Wandabstand (lichtes Maß)</p> <p>D60 / 100 mm: 200 mm D80 / 125 mm: 175 mm D100 / 150 mm: 150 mm D110 / 160 mm: 140 mm</p>
	<p>Wandkonsole mit Querstrebe Type 392 max. Wandabstand (lichtes Maß)</p> <p>D60 / 100 mm: 350 mm D80 / 125 mm: 325 mm D100 / 150 mm: 300 mm D110 / 160 mm: 290 mm</p>
	<p>Wandkonsole mit Querstrebe Type 393 max. Wandabstand (lichtes Maß)</p> <p>D60 / 100 mm: 600 mm D80 / 125 mm: 575 mm D100 / 150 mm: 550 mm D110 / 160 mm: 540 mm</p>
	<p>Wandkonsole mit Querstrebe Type 407 max. Wandabstand (lichtes Maß)</p> <p>D60 / 100 mm: 880 mm D80 / 125 mm: 855 mm D100 / 150 mm: 830 mm D110 / 160 mm: 820 mm</p>
	<p>Fußteil „offen“ als Zwischenstütze D60 / 100 mm, Nutzlänge: 90 mm</p>

		<p>Fußteil „offen“ als Zwischenstütze D80 / 125 mm, Nutzlänge: 90 mm</p>
		<p>Fußteil „offen“ als Zwischenstütze D100 / 150 mm, Nutzlänge: 90 mm</p>
		<p>Fußteil „offen“ als Zwischenstütze D110 / 160 mm, Nutzlänge: 90 mm</p>
		<p>Fußteil „offen“ als Zwischenstütze mit integrierter Zuluftansaugung D60 / 100 mm, Nutzlänge: 190 mm</p>
		<p>Fußteil „offen“ als Zwischenstütze mit integrierter Zuluftansaugung D80 / 125 mm, Nutzlänge: 190 mm</p>



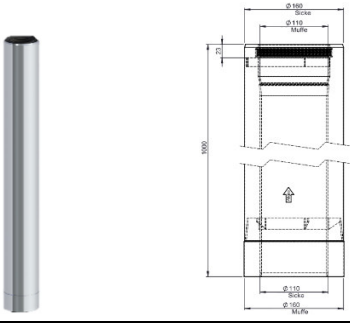
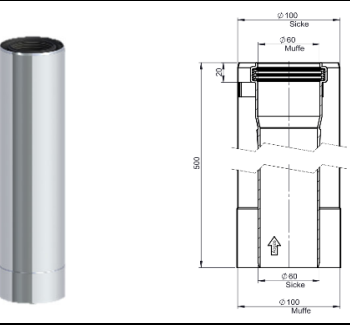
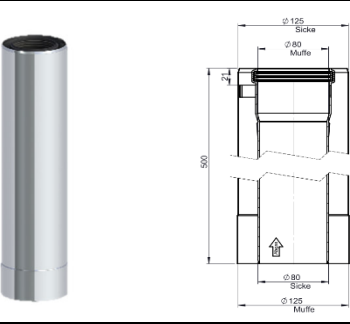
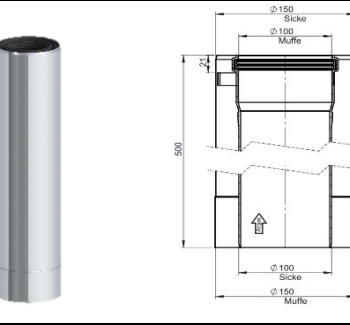
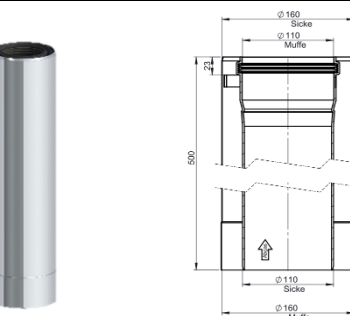

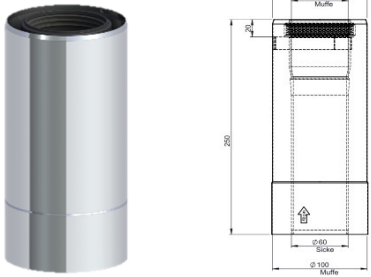
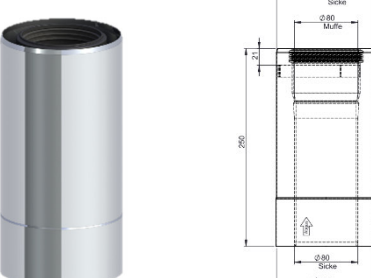
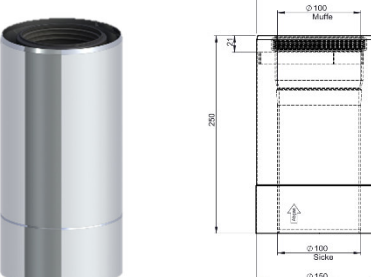
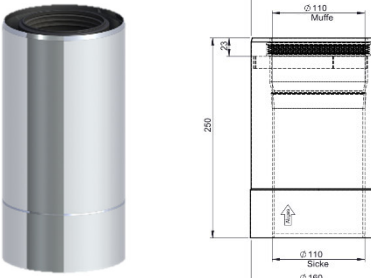
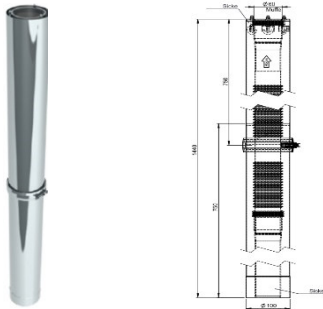

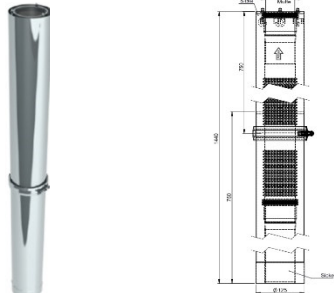
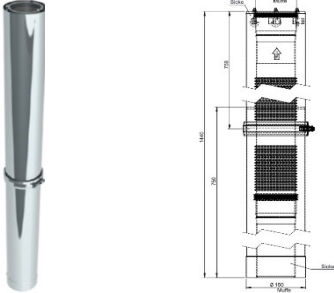
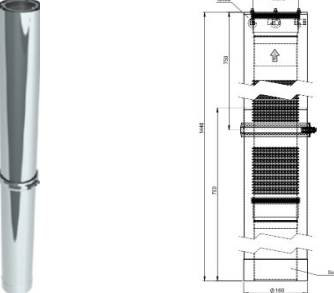
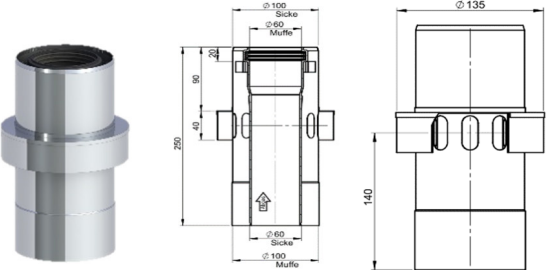
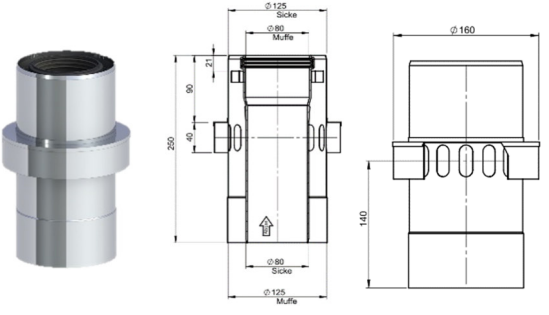

	<p>Fußteil „offen“ als Zwischenstütze mit integrierter Zuluftansaugung D100 / 150 mm, Nutzlänge: 190 mm</p>
	<p>Fußteil „offen“ als Zwischenstütze mit integrierter Zuluftansaugung D110 / 160 mm, Nutzlänge: 190 mm</p>
	<p>Rohrelement Länge 1000 mm D60 / 100 mm, Nutzlänge: 940 mm</p>
	<p>Rohrelement Länge 1000 mm D80 / 125 mm, Nutzlänge: 940 mm</p>
	<p>Rohrelement Länge 1000 mm D100 / 150 mm, Nutzlänge: 940 mm</p>

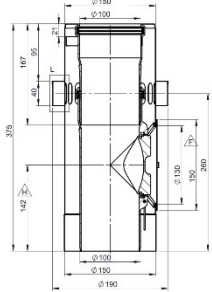
	<p>Rohrelement Länge 1000 mm D110 / 160 mm, Nutzlänge: 940 mm</p>
	<p>Rohrelement Länge 500 mm D60 / 100 mm, Nutzlänge: 440 mm</p>
	<p>Rohrelement Länge 500 mm D80 / 125 mm, Nutzlänge: 440 mm</p>
	<p>Rohrelement Länge 500 mm D100 / 150 mm, Nutzlänge: 440 mm</p>
	<p>Rohrelement Länge 500 mm D110 / 160 mm, Nutzlänge: 440 mm</p>

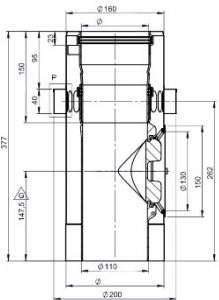
	<p>Rohrelement Länge 250 mm D60 / 100 mm, Nutzlänge: 190 mm</p>
	<p>Rohrelement Länge 250 mm D80 / 125 mm, Nutzlänge: 190 mm</p>
	<p>Rohrelement Länge 250 mm D100 / 150 mm, Nutzlänge: 190 mm</p>
	<p>Rohrelement Länge 250 mm D110 / 160 mm, Nutzlänge: 255 mm</p>
	<p>Teleskopkompensator LAS PP-ES D60 / 100 mm, Nutzlänge: 1380 mm</p>

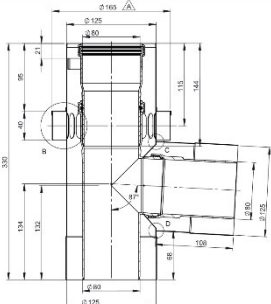
	<p>Teleskopkompensator LAS PP-ES D80 / 125 mm, Nutzlänge: 1380 mm</p>
	<p>Teleskopkompensator LAS PP-ES D100 / 150 mm, Nutzlänge: 1380 mm</p>
	<p>Teleskopkompensator LAS PP-ES D110 / 160 mm, Nutzlänge: 1380 mm</p>
	<p>Zuluftelement D60 / 100 mm, Nutzlänge: 190 mm</p>
	<p>Zuluftelement D80 / 125 mm, Nutzlänge: 190 mm</p>

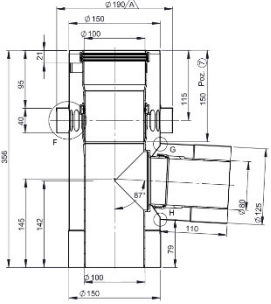
	<p>Zuluftelement D100 / 150 mm, Nutzlänge: 190 mm</p>																																								
	<p>Zuluftelement D110 / 160 mm, Nutzlänge: 190 mm</p>																																								
	<p>Reinigungselement D60 / 100 mm bis 110 / 160 mm, Nutzlänge: 242 mm</p> <table border="1"> <thead> <tr> <th>Ø</th> <th>060/100</th> <th>080/125</th> <th>100/150</th> <th>110/160</th> </tr> </thead> <tbody> <tr> <td>A</td> <td>60</td> <td>80</td> <td>100</td> <td>110</td> </tr> <tr> <td>B</td> <td>100</td> <td>125</td> <td>150</td> <td>160</td> </tr> <tr> <td>C</td> <td>80</td> <td>120</td> <td colspan="2">130</td> </tr> <tr> <td>D</td> <td>100</td> <td>140</td> <td colspan="2">150</td> </tr> <tr> <td>E</td> <td>150</td> <td>144</td> <td>167</td> <td>-</td> </tr> <tr> <td>F</td> <td>118</td> <td>131,5</td> <td>142</td> <td>147,5</td> </tr> <tr> <td>G</td> <td>302</td> <td>330</td> <td>375</td> <td>290</td> </tr> </tbody> </table>	Ø	060/100	080/125	100/150	110/160	A	60	80	100	110	B	100	125	150	160	C	80	120	130		D	100	140	150		E	150	144	167	-	F	118	131,5	142	147,5	G	302	330	375	290
Ø	060/100	080/125	100/150	110/160																																					
A	60	80	100	110																																					
B	100	125	150	160																																					
C	80	120	130																																						
D	100	140	150																																						
E	150	144	167	-																																					
F	118	131,5	142	147,5																																					
G	302	330	375	290																																					
	<p>Reinigungselement mit Zuluftansaugung D60 / 100 mm, Nutzlänge: 270 mm</p>																																								
	<p>Reinigungselement mit Zuluftansaugung D80 / 125 mm, Nutzlänge: 270 mm</p>																																								

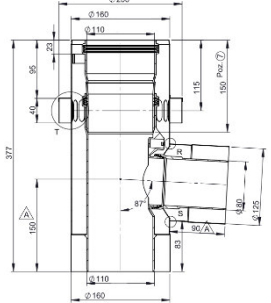
		<p>Reinigungselement mit Zuluftansaugung D100 / 150 mm, Nutzlänge: 315 mm</p>
		<p>Reinigungselement mit Zuluftansaugung D110 / 160 mm, Nutzlänge: 317 mm</p>
		<p>T-Stück-mit-Zuluft-für-Mehrfachbelegung D80 / 125 mm, Nutzlänge: 270 mm</p>
		<p>T-Stück-mit-Zuluft-für-Mehrfachbelegung D100 / 150 mm, Nutzlänge: 296 mm</p>
		<p>T-Stück-mit-Zuluft-für-Mehrfachbelegung D110 / 160 mm, Nutzlänge: 317 mm</p>

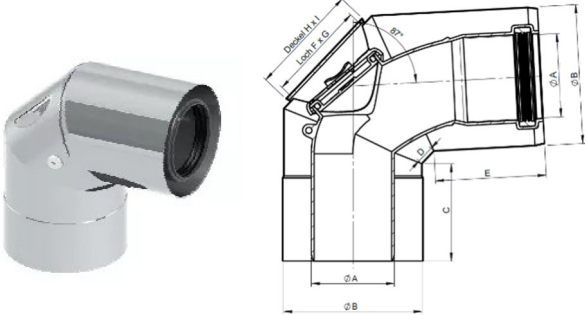
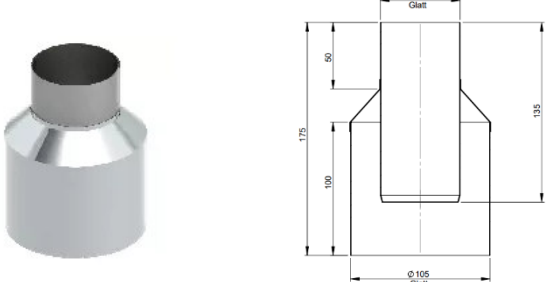
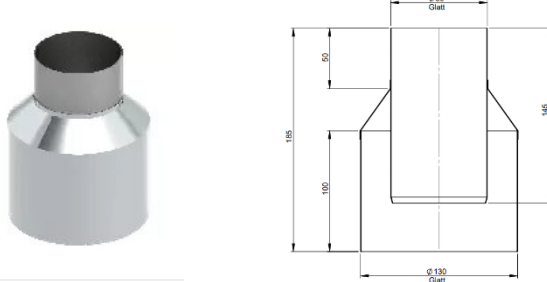
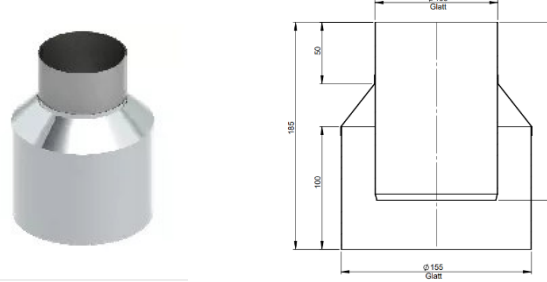
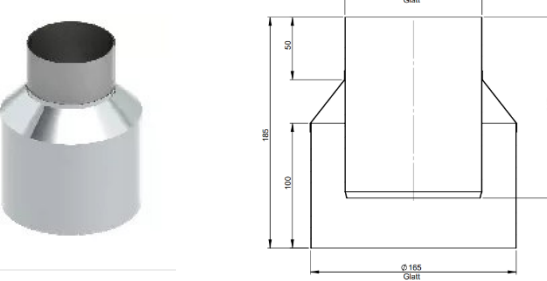
	<p>Winkel 87° mit Revisionsöffnung D60 / 100 bis 110 / 160 mm</p> <table border="1" data-bbox="794 488 1158 757"> <thead> <tr> <th>Ø</th> <th>060/100</th> <th>080/125</th> <th>100/150</th> <th>110/160</th> </tr> </thead> <tbody> <tr> <td>A</td> <td>60</td> <td>80</td> <td>100</td> <td>110</td> </tr> <tr> <td>B</td> <td>100</td> <td>125</td> <td>150</td> <td>160</td> </tr> <tr> <td>C</td> <td>70</td> <td>93,8</td> <td>80</td> <td>80</td> </tr> <tr> <td>D</td> <td>12,5</td> <td>12,5</td> <td>35</td> <td>35</td> </tr> <tr> <td>E</td> <td>80</td> <td>78,5</td> <td>80</td> <td>80</td> </tr> <tr> <td>F</td> <td>72</td> <td>89</td> <td>130</td> <td>130</td> </tr> <tr> <td>G</td> <td>120</td> <td>89</td> <td>130</td> <td>130</td> </tr> <tr> <td>H</td> <td>80</td> <td>98</td> <td>150</td> <td>150</td> </tr> <tr> <td>I</td> <td>165</td> <td>98</td> <td>150</td> <td>150</td> </tr> <tr> <td>kg</td> <td>0,46</td> <td>0,67</td> <td>0,86</td> <td>1,04</td> </tr> </tbody> </table>	Ø	060/100	080/125	100/150	110/160	A	60	80	100	110	B	100	125	150	160	C	70	93,8	80	80	D	12,5	12,5	35	35	E	80	78,5	80	80	F	72	89	130	130	G	120	89	130	130	H	80	98	150	150	I	165	98	150	150	kg	0,46	0,67	0,86	1,04
Ø	060/100	080/125	100/150	110/160																																																				
A	60	80	100	110																																																				
B	100	125	150	160																																																				
C	70	93,8	80	80																																																				
D	12,5	12,5	35	35																																																				
E	80	78,5	80	80																																																				
F	72	89	130	130																																																				
G	120	89	130	130																																																				
H	80	98	150	150																																																				
I	165	98	150	150																																																				
kg	0,46	0,67	0,86	1,04																																																				
	<p>Mündungsabschlussstück D60 / 105 mm, Nutzlänge: 115 mm</p>																																																							
	<p>Mündungsabschlussstück D80 / 130 mm, Nutzlänge: 125 mm</p>																																																							
	<p>Mündungsabschlussstück D100 / 155 mm, Nutzlänge: 125 mm</p>																																																							
	<p>Mündungsabschlussstück D110 / 165 mm, Nutzlänge: 125 mm</p>																																																							

	<p>Regenkragen / Wandrosette (Ringbreite ca. 75 mm)</p> <table border="1"> <tr> <td>ϕ</td> <td>80</td> <td>100</td> <td>110</td> <td>115</td> <td>120</td> <td>130</td> <td>140</td> <td>150</td> <td>160</td> </tr> <tr> <td>A</td> <td>80</td> <td>100</td> <td>110</td> <td>115</td> <td>120</td> <td>130</td> <td>140</td> <td>150</td> <td>160</td> </tr> <tr> <td>C</td> <td colspan="8">15</td> <td>25</td> </tr> <tr> <td>kg</td> <td>0,17</td> <td>0,19</td> <td>0,2</td> <td>0,21</td> <td>0,21</td> <td>0,22</td> <td>0,23</td> <td>0,24</td> <td>0,25</td> </tr> </table>	ϕ	80	100	110	115	120	130	140	150	160	A	80	100	110	115	120	130	140	150	160	C	15								25	kg	0,17	0,19	0,2	0,21	0,21	0,22	0,23	0,24	0,25
ϕ	80	100	110	115	120	130	140	150	160																																
A	80	100	110	115	120	130	140	150	160																																
C	15								25																																
kg	0,17	0,19	0,2	0,21	0,21	0,22	0,23	0,24	0,25																																
<p>Ansicht A-A Maßstab 1 : 6</p>	<p>Grundplatte für Kaminerrhöhung ohne Einschub D100</p>																																								
<p>Ansicht A-A Maßstab 1 : 6</p>	<p>Grundplatte für Kaminerrhöhung ohne Einschub D125</p>																																								
<p>Ansicht A-A Maßstab 1 : 6</p>	<p>Grundplatte für Kaminerrhöhung ohne Einschub D150</p>																																								
<p>Ansicht A-A Maßstab 1 : 6</p>	<p>Grundplatte für Kaminerrhöhung ohne Einschub D160</p>																																								

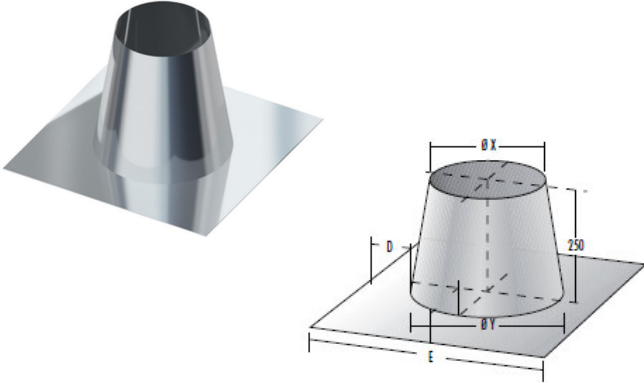

Dachdurchführung „Flachdach“ mit Stahlschürze
Für LAS System D 60/100 mm, D 80/125 mm, D 100/150 mm, D 110/160 mm

h	250
ØX	170
ØY	270
E	666
D	198

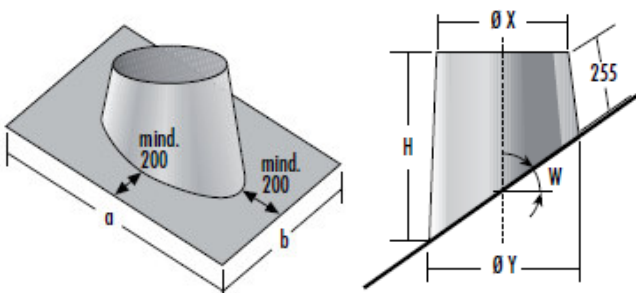

Dachdurchführungen mit Bleischürze
Für LAS-System D60/100; D 80/125 mm, D 100/150 mm, D 110/160 mm

h bei 5°	279
h bei 15°	327
h bei 25°	381
h bei 35°	444
h bei 45°	525
h bei 55°	641
ØX	170
ØY	270

Neigungen:
0°-10°/11°-20°/21°-30°/31°-40°/41°-50°/51°-60°

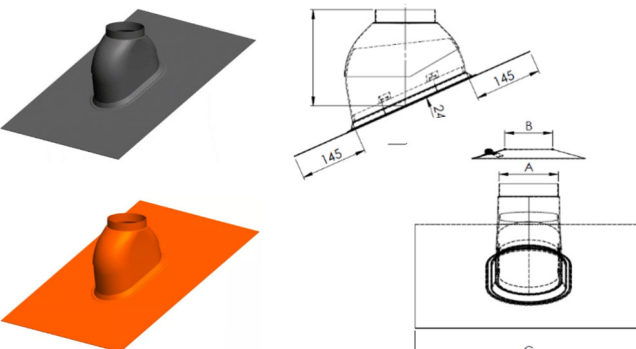

Dachdurchführung (Wakaflex) 0-48° – ohne Regenkragen, schwarz oder rot
D60 / 100 mm
D80 / 125 mm
D110 / 160 mm

DN	60	80	110
A	131	131	166
B	100	125	160
C	500x560	500x560	560x715

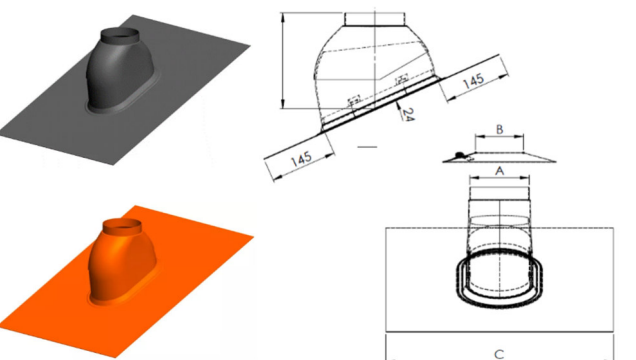

Dachdurchführung (Wakaflex) 25-45° – ohne Regenkragen 500x500 mm, schwarz oder rot
D100 / 150 mm

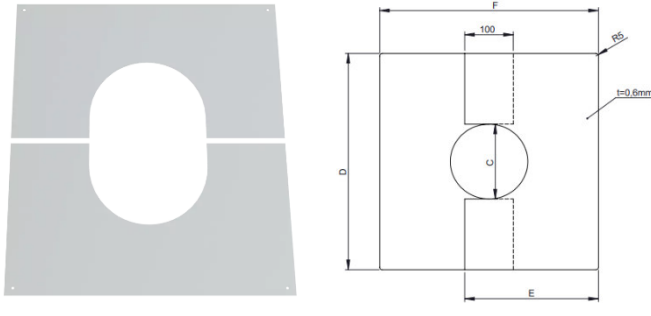
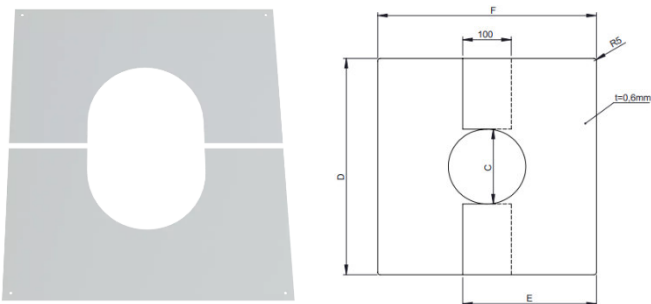
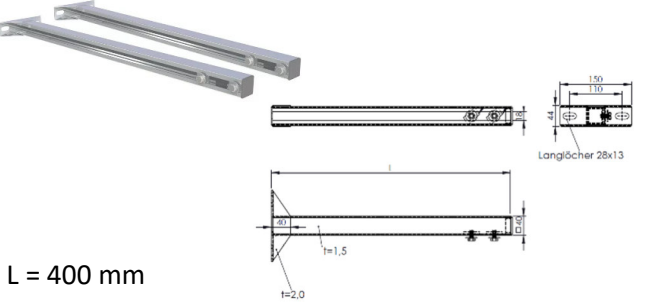
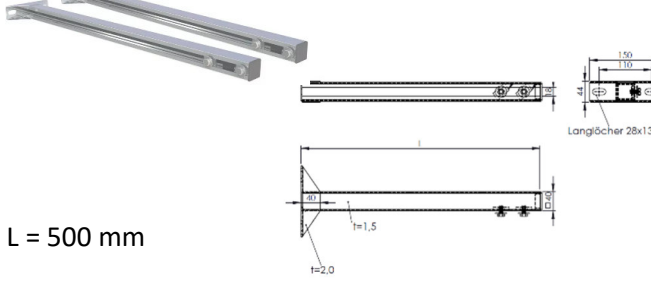
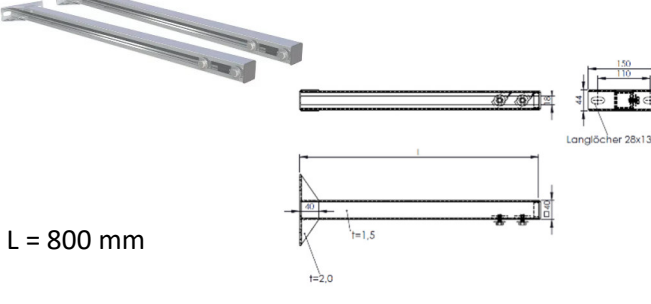
	<p>Blendblech zweiteilig 0-30°</p> <table border="1" data-bbox="794 300 1417 546"> <thead> <tr> <th>Ø</th> <th>100</th> <th>125</th> <th>150</th> <th>160</th> </tr> </thead> <tbody> <tr> <td>C</td> <td>103</td> <td>128</td> <td>154</td> <td>163</td> </tr> <tr> <td>D</td> <td>395</td> <td>420</td> <td>445</td> <td>455</td> </tr> <tr> <td>E</td> <td>261,0</td> <td>276</td> <td>292</td> <td>298</td> </tr> <tr> <td>F</td> <td>421</td> <td>453</td> <td>484</td> <td>497</td> </tr> <tr> <td>kg</td> <td>0,88</td> <td>0,96</td> <td>1,05</td> <td>1,08</td> </tr> </tbody> </table>	Ø	100	125	150	160	C	103	128	154	163	D	395	420	445	455	E	261,0	276	292	298	F	421	453	484	497	kg	0,88	0,96	1,05	1,08
Ø	100	125	150	160																											
C	103	128	154	163																											
D	395	420	445	455																											
E	261,0	276	292	298																											
F	421	453	484	497																											
kg	0,88	0,96	1,05	1,08																											
	<p>Blendblech zweiteilig 31-45°</p> <table border="1" data-bbox="794 640 1417 887"> <thead> <tr> <th>Ø</th> <th>100</th> <th>125</th> <th>150</th> <th>160</th> </tr> </thead> <tbody> <tr> <td>C</td> <td>103</td> <td>128</td> <td>154</td> <td>163</td> </tr> <tr> <td>D</td> <td>395</td> <td>420</td> <td>445</td> <td>455</td> </tr> <tr> <td>E</td> <td>261,0</td> <td>276</td> <td>292</td> <td>298</td> </tr> <tr> <td>F</td> <td>421</td> <td>453</td> <td>484</td> <td>497</td> </tr> <tr> <td>kg</td> <td>0,88</td> <td>0,96</td> <td>1,05</td> <td>1,08</td> </tr> </tbody> </table>	Ø	100	125	150	160	C	103	128	154	163	D	395	420	445	455	E	261,0	276	292	298	F	421	453	484	497	kg	0,88	0,96	1,05	1,08
Ø	100	125	150	160																											
C	103	128	154	163																											
D	395	420	445	455																											
E	261,0	276	292	298																											
F	421	453	484	497																											
kg	0,88	0,96	1,05	1,08																											
 <p>L = 400 mm</p>	<p>Verlängerung für Wandhalter Type 706 max. Wandabstand (lichtes Maß)</p> <p>D60 / 100 mm: 350 mm D80 / 125 mm: 337 mm D100 / 150 mm: 325 mm D110 / 160 mm: 320 mm</p>																														
 <p>L = 500 mm</p>	<p>Verlängerung für Wandhalter Type 709 max. Wandabstand (lichtes Maß)</p> <p>D60 / 100 mm: 450 mm D80 / 125 mm: 437 mm D100 / 150 mm: 425 mm D110 / 160 mm: 420 mm</p>																														
 <p>L = 800 mm</p>	<p>Verlängerung für Wandhalter Type 710 max. Wandabstand (lichtes Maß)</p> <p>D60 / 100 mm: 750 mm D80 / 125 mm: 737 mm D100 / 150 mm: 725 mm D110 / 160 mm: 720 mm</p>																														

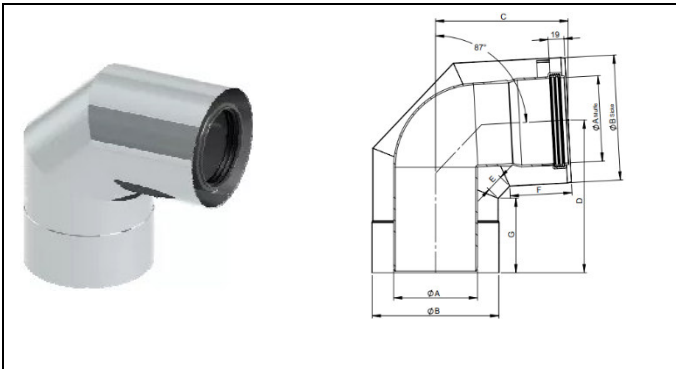

Winkel 87°

ϕ	60/100	80/125	100/150	110/160
A	60	80	100	110
B	100	125	150	160
C	135	147	157	163
D	157	169	182	187
E	12,5	20	12,5	20
F	80	74	77	80
G	80	88	92	80
kg	0,49	0,61	0,79	0,9

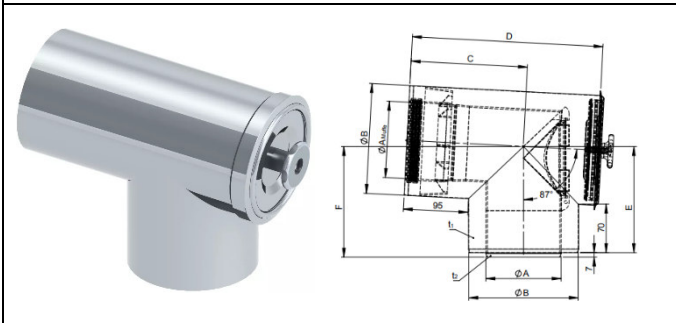

T-Anschluss 87° mit Revisionsdeckel und integriertem Kesselanschluss, Abgang „gleich“

ϕ	60/100	80/125	100/150	110/160
A	60	80	100	110
B	100	125	150	160
C	142	155	166	171
D	220	245	270	280
E	124	137	150	156
F	136	149	161	166

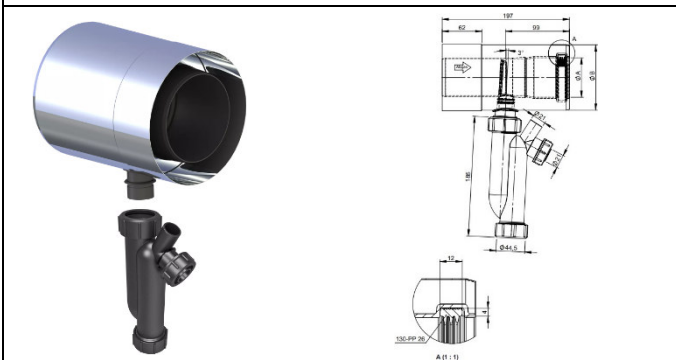

Kondensatablauf inkl. Siphon für horizontalen Einbau

ϕ	60/100	80/125	100/150	110/160
A	60	80	100	110
B	100	125	150	160
kg	0,40	0,48	0,59	0,64

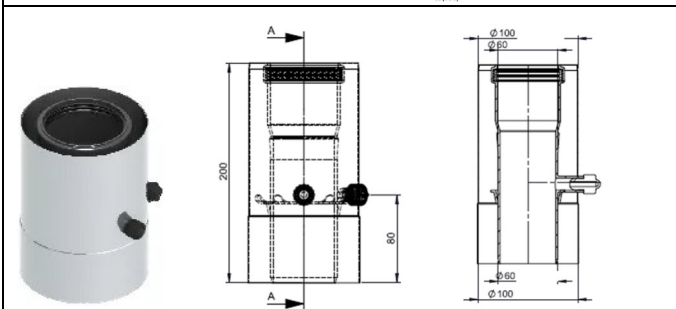

Messelement
D60/100, Nutzlänge: 140 mm

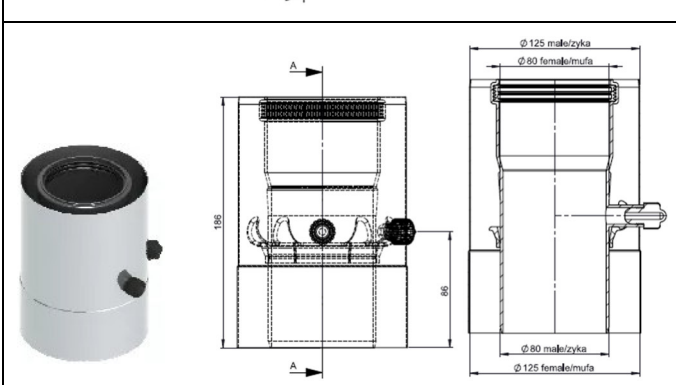

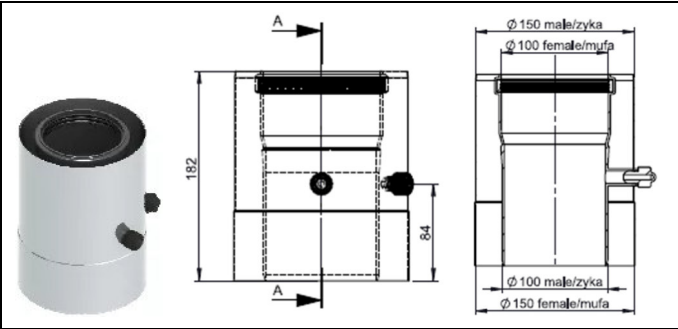
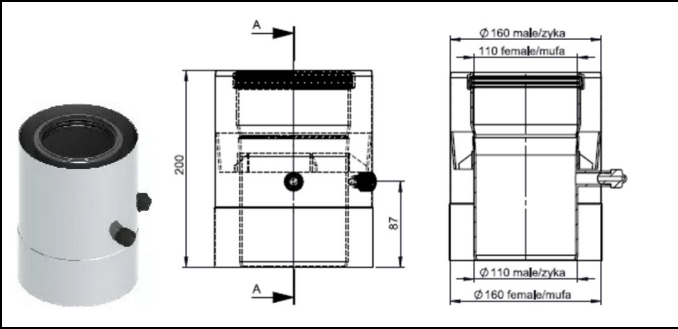
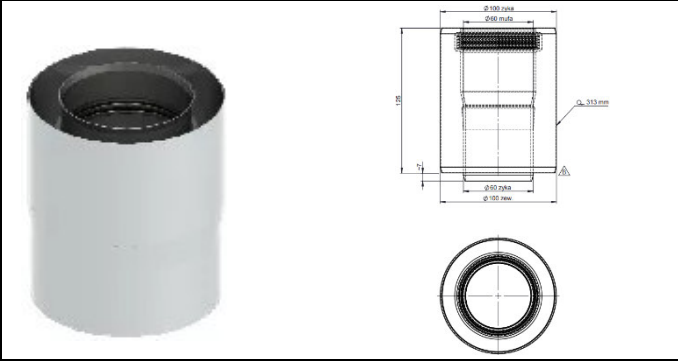
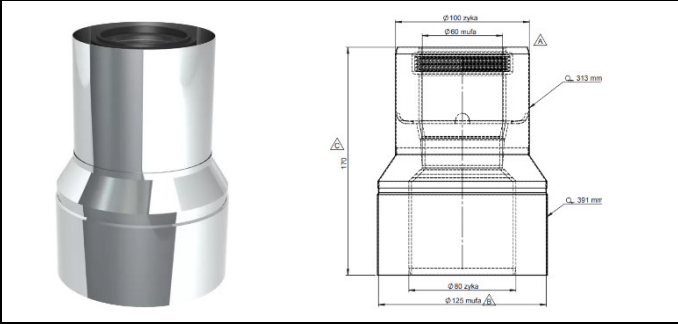
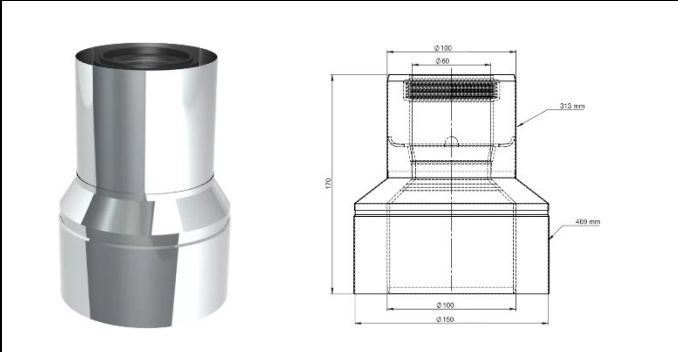

Messelement
D80/125, Nutzlänge: 126 mm

	<p>Messelement D100/150, Nutzlänge: 122 mm</p>
	<p>Messelement D110/160, Nutzlänge: 140 mm</p>
	<p>Kesselanschluss, Abgang „gleich“ (ohne Messöffnung), Nutzlänge: 65 mm</p> <p>D60 / 100 mm D80 / 125 mm D100 / 150 mm D110 / 160 mm</p>
	<p>Reduzierung, konzentrisch (von Kesselstutzen zur Abgasanlage) D80/125 auf D60/100, Nutzlänge: 110 mm</p>
	<p>Reduzierung, konzentrisch (von Kesselstutzen zur Abgasanlage) D100/150 auf D60/100, Nutzlänge: 110 mm</p>

	<p>Reduzierung, konzentrisch (von Kesselstutzen zur Abgasanlage) D100/150 auf D80/125, Nutzlänge: 110 mm</p>
	<p>Reduzierung, konzentrisch (von Kesselstutzen zur Abgasanlage) D110/160 auf D60/100, Nutzlänge: 120 mm</p>
	<p>Reduzierung, konzentrisch (von Kesselstutzen zur Abgasanlage) D110/160 auf D80/125, Nutzlänge: 110 mm</p>
	<p>Reduzierung, konzentrisch (von Kesselstutzen zur Abgasanlage) D110/160 auf D100/150, Nutzlänge: 110 mm</p>
	<p>Erweiterung, konzentrisch (von Kesselstutzen zur Abgasanlage) D60/100 auf D80/125, Nutzlänge: 96 mm</p>

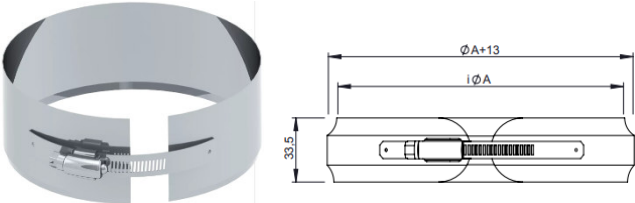
	<p>Erweiterung, konzentrisch (von Kesselstutzen zur Abgasanlage) D60/100 auf D100/150, Nutzlänge: 110 mm</p>
	<p>Erweiterung, konzentrisch (von Kesselstutzen zur Abgasanlage) D60/100 auf D110/160, Nutzlänge: 71 mm</p>
	<p>Erweiterung, konzentrisch (von Kesselstutzen zur Abgasanlage) D80/125 auf D100/150, Nutzlänge: 90 mm</p>
	<p>Erweiterung, konzentrisch (von Kesselstutzen zur Abgasanlage) D80/125 auf D110/160, Nutzlänge: 110 mm</p>
	<p>Erweiterung, konzentrisch (von Kesselstutzen zur Abgasanlage) D100/150 auf D110/160, Nutzlänge: 85 mm</p>

	<p>Dichtring (EPDM) Ersatz für PP-Innenrohr (innenliegend) D60 bis 110</p>																				
	<p>Klemmband für Außenmontage</p> <table border="1" data-bbox="798 689 1417 815"> <tr> <td>Ø</td> <td>100</td> <td>125</td> <td>150</td> <td>160</td> </tr> <tr> <td>A</td> <td>105</td> <td>130</td> <td>155</td> <td>165</td> </tr> <tr> <td>kg</td> <td>0,1</td> <td>0,1</td> <td>0,2</td> <td>0,2</td> </tr> </table>	Ø	100	125	150	160	A	105	130	155	165	kg	0,1	0,1	0,2	0,2					
Ø	100	125	150	160																	
A	105	130	155	165																	
kg	0,1	0,1	0,2	0,2																	
	<p>Klemmband mit Außendichtung (für Innenmontage zwingend erforderlich)</p> <table border="1" data-bbox="798 1021 1417 1191"> <tr> <td>Ø</td> <td>100</td> <td>125</td> <td>150</td> <td>160</td> </tr> <tr> <td>A</td> <td>100</td> <td>125</td> <td>160</td> <td>160</td> </tr> <tr> <td>B</td> <td>110</td> <td>135</td> <td>170</td> <td>170</td> </tr> <tr> <td>C</td> <td>400</td> <td>570</td> <td>592</td> <td>592</td> </tr> </table>	Ø	100	125	150	160	A	100	125	160	160	B	110	135	170	170	C	400	570	592	592
Ø	100	125	150	160																	
A	100	125	160	160																	
B	110	135	170	170																	
C	400	570	592	592																	